

2/2-Way; G 1/4"-2"; PN 0-10 bar



Advantages/Benefits

- ▶ Waterhammer-free
- ▶ Low noise
- ▶ Zero differential pressure
- ▶ Compact design with high flow rates
- ▶ Low maintenance
- ▶ Coil can be locked in 4 x 90° positions, or moved freely between, as required
- ▶ Modular solenoid coil system, different sizes and power ratings
- ▶ Easy coil change
- ▶ Wide range of cable plug options Type 2508

Design/Function

The valves are based on a modular concept comprising three basic elements: Valve assembly, push-over coil and standard cable plug. The servo-system with coupled diaphragm/armature assembly and armature guide tube is mounted on the valve body. The coil is pushed over the armature guide tube and thus isolated from the medium. The medium is only in contact with the valve internals and body.

All valves operate from zero pressure.

A wide selection of pipe and orifice sizes is offered. Valves are available with threaded ports in brass and Stainless Steel.

To simplify ordering, a wide selection of standard combinations of valve body, push-over coil and standard cable plug can be ordered with one item number.

Cable plug options of Type 2508 and 2511 HL are available to suit special electrical application requirements.

- The modular concept provides flexibility to meet application requirements.

Applications

Fluids

- Neutral liquids, e.g. water, oils and fat
- Per-solutions, hot oils and oils with additives

Applications

- Process systems
- Chemical processing
- Water treatment
- General purpose applications
- Sterilizers

Technical Data Type 6213

Circuit function

A 2/2-way, normally closed, with coupled diaphragm

Symbol

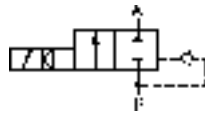

Operating Data (Valve)

Pressure range	0-10 bar
Port connection	G 1/4" - G 2"
Fluid	
Seal material NBR:	Neutral liquids e.g. water, oils and fat without additives.
Seal material FPM:	Per-solutions, hot oils, oils with additives
Seal material EPDM:	Please see data sheet "6213 Hot Water Range"
Medium temperature	-10 ... +90 °C (Seal NBR) -10 ... +100 °C (Seal FPM) -30 ... +120 °C (Seal EPDM)
Max. ambient temperature	+55 °C
Max. viscosity	21 mm ² /s
Response times	opening: 50- 700 ms ¹⁾ closing: 100-2500 ms ¹⁾ ¹⁾ Depend on orifice, fluid pressure and viscosity.
Installation	as required, but preferably with solenoid system upright

Operating Data (Actuator)

Operating voltages	AC 24, 110, 230 V/50Hz DC 24 V/=*				
Standard versions:	(*only DN 10-20)				
Heavy duty versions:	AC 24, 110, 230 V/50-60Hz DC 24 V/UC* (*incl. DN 25/40 norm. version)				
Voltages tolerance	±10 %				
Power consumption (AC)	Standard versions:				
DN [mm]	10	13	20	25	40
Inrush	34VA	36VA	38VA	160VA	202VA
Hold	14VA/8W	14VA/8W	14VA/8W	38VA/18W	38VA/18W
	Heavy duty versions:				
DN [mm]	13	20			
Inrush	100VA	150VA			
Hold	28VA/15W	38VA/18W			
Power consumption (DC)	Standard versions:				
DN [mm]	10	13	20		
Inrush	10W	10W	10W		
Hold	10W	10W	10W		
	Heavy duty UC versions* (*incl. DN 25/40 norm. version)				
DN [mm]	13	20	(with cable plug 2511 HL)		
Inrush	60W	72W			
Hold	3W	4W			
Duty cycle	100% continuously rated				
Cycling rate	up to 15 c.p.m.				
Protection class	IP 65				
Electr. connection	Delivery standard: Cable plug DIN 43 650 A, 0-250 V (other versions see accessories) Cable plug 2511 HL for 24 V/UC heavy duty and 24 V/UC DN25 / DN40				

Materials

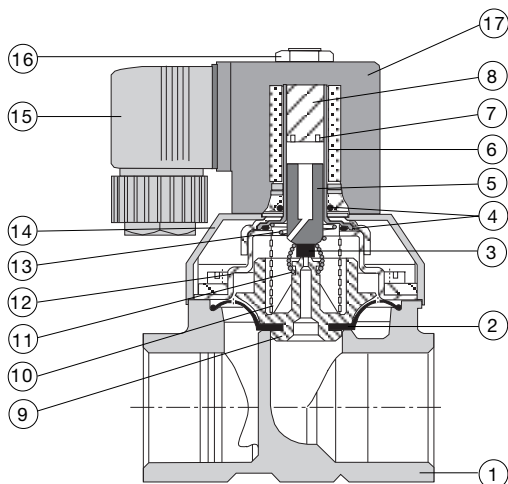

1	Valve body:	Brass and Stainless Steel
2	Diaphragm:	NBR, FPM
3	Plunger-seal:	NBR, FPM
4	O-rings:	NBR, FPM
5	Plunger:	1.4105
6	Armature guide tube:	1.4301
7	Shading ring:	Cu (copper)
8	Stopper:	1.4105
9	Diaphragm support:	PPSGF40
10	Spring:	1.4310
11	Tension spring:	1.4310
12	Bonnet:	1.4301
13	Taper spring:	1.4310
14	Bonnet:	Durethan BKV30H
15	Cable plug:	PA (Polyamide)
16	Locknut:	9SMnPb28K (surface Zn5glcA)
17	Coil:	Polyamide (DN 10-20 mm) Epoxy (DN 25-40 mm)

Solenoid Valve, waterhammer-free, 0-10 bar

General Purpose

Type 6213

Specifications - Ordering Chart (Other Versions on Request)

Circuit Function: A (with standard-cable plug)
Temperature range -10°C ... +90°C; brass body; seal material NBR 0-250 V AC/DC

Port connection [Inch]	Orifice [mm]	Kv-value (water) [m³/h]	Pressure Range [bar]	Seal material	Weight [kg]	ITEM - NO.			
						Voltage / Frequency			
						24/=	24/50	110/50	230/50
G 1/4	10.0	2.0	0-10	NBR	0.40	139 100 E	139 101 T	139 102 U	139 103 V
G 3/8	10.0	2.0	0-10	NBR	0.40	125 653 V	125 654 W	125 655 X	125 656 Y
G 1/2	13.0	3.6	0-10	NBR	0.55	125 657 Z	125 658 A	125 659 B	125 660 G
G 3/4	20.0	9.0	0-10	NBR	1.00	126 284 M	126 285 N	126 286 P	126 287 Q
G 1	25.0	11.0	0-10	NBR	1.70	138 410 T**	134 678 F	134 679 G	134 680 W
G 1 1/4	25.0	11.0	0-10	NBR	1.70	138 411 Q**	134 681 K	134 682 L	134 683 M
G 1 1/2	40.0	30.0	0-10	NBR	3.60	138 416 M**	134 684 N	134 685 P	134 686 Q
G 2	40.0	30.0	0-10	NBR	3.60	138 417 N**	134 687 R	134 688 S	134 689 T

** with cable plug 2511 HL for UC

Circuit Function: A (with standard-cable plug)
Temperature range -10°C ... +100°C; brass body; seal material FPM 0-250 V AC/DC

Port connection [Inch]	Orifice [mm]	Kv-value (water) [m³/h]	Pressure Range [bar]	Seal material	Weight [kg]	ITEM - NO.			
						Voltage / Frequency			
						24/=	24/50	110/50	230/50
G 1/4	10.0	2.0	0-10	FPM	0.40	139 104 W	139 105 X	139 106 Y	139 107 Z
G 3/8	10.0	2.0	0-10	FPM	0.40	126 264 Y	126 265 Z	126 266 S	126 267 T
G 1/2	13.0	3.6	0-10	FPM	0.55	126 276 U	126 277 V	126 278 E	126 279 F
G 3/4	20.0	9.0	0-10	FPM	1.00	126 292 M	126 293 N	126 294 P	126 295 Q
G 1	25.0	11.0	0-10	FPM	1.70	138 414 K**	135 139 L	135 140 Z	135 141 N
G 1 1/4	25.0	11.0	0-10	FPM	1.70	138 415 L**	135 142 P	135 143 Q	135 144 R
G 1 1/2	40.0	30.0	0-10	FPM	3.60	138 420 V**	135 242 T	135 243 U	135 244 V
G 2	40.0	30.0	0-10	FPM	3.60	138 421 J**	135 245 W	135 246 X	135 247 Y

** with cable plug 2511 HL for UC

Circuit Function: A (with standard-cable plug)
Temperature range -10°C ... +90°C; Stainless Steel body; seal material NBR 0-250 V AC/DC

Port connection [Inch]	Orifice [mm]	Kv-value (water) [m³/h]	Pressure Range [bar]	Seal material	Weight [kg]	ITEM - NO.			
						Voltage / Frequency			
						24/=	24/50	110/50	230/50
G 1/4	10.0	2.0	0-10	NBR	0.40	141 175 W	141 176 X	141 177 Y	141 178 H
G 3/8	10.0	2.0	0-10	NBR	0.40	141 179 A	141 180 Y	141 181 M	141 182 N
G 1/2	13.0	3.6	0-10	NBR	0.55	141 207 F	141 208 Q	141 209 R	141 210 D
G 3/4	20.0	9.0	0-10	NBR	1.10	141 231 W	141 232 X	141 233 Y	141 234 Z

Circuit Function: A (with standard-cable plug)
Temperature range -10°C ... +90°C; Stainless Steel body; seal material FPM 0-250 V AC/DC

Port connection [Inch]	Orifice [mm]	Kv-value (water) [m³/h]	Pressure Range [bar]	Seal material	Weight [kg]	ITEM - NO.			
						Voltage / Frequency			
						24/=	24/50	110/50	230/50
G 1/4	10.0	2.0	0-10	FPM	0.40	141 187 K	141 188 U	141 189 V	141 190 S
G 3/8	10.0	2.0	0-10	FPM	0.40	141 191 P	141 192 Q	141 193 R	141 194 J
G 1/2	13.0	3.6	0-10	FPM	0.55	141 215 W	141 216 X	141 217 Y	141 218 H
G 3/4	20.0	9.0	0-10	FPM	1.10	141 239 E	141 240 K	141 241 G	141 242 H

Circuit Function: A / for heavy duty applications (with standard-cable plug)
Temperature range -10°C ... +90°C; brass body; seal material NBR 0-250 V AC/DC

Port connection [Inch]	Orifice [mm]	Kv-value (water) [m³/h]	Pressure Range [bar]	Seal material	Weight [kg]	ITEM - NO.			
						Voltage / Frequency			
						24/UC	24/50-60	110/50-60	230/50-60
G 1/2	13.0	3.6	0-10	NBR	0.78	138 754 F**	136 668 F	136 669 G	136 670 D
G 3/4	13.0	3.6	0-10	NBR	0.78	138 755 G**	136 671 S	136 672 T	136 673 U
G 3/4	20.0	9.0	0-10	NBR	1.47	138 756 H**	136 674 V	136 675 W	136 676 X
G 1	20.0	9.0	0-10	NBR	1.47	138 757 A**	136 677 Y	136 678 H	136 679 A

** with cable plug 2511 HL

Circuit Function: A / for heavy duty applications (with standard-cable plug)
Temperature range -10°C ... +90°C; Stainless Steel body; seal material FPM 0-250 V AC/DC

Port connection [Inch]	Orifice [mm]	Kv-value (water) [m³/h]	Pressure Range [bar]	Seal material	Weight [kg]	ITEM - NO.			
						Voltage / Frequency			
						24/UC	24/50-60	110/50-60	230/50-60
G 1/2	13.0	3.6	0-10	FPM	0.78	141 817 J**	141 818 T	141 819 U	141 820 Z
G 3/4	20.0	9.0	0-10	FPM	1.47	141 821 N**	141 822 P	141 823 Q	141 824 R
G 1	20.0	9.0	0-10	FPM	1.47	141 825 J**	141 826 K	141 827 L	141 828 V

** with cable plug 2511 HL

Dimensions [mm]

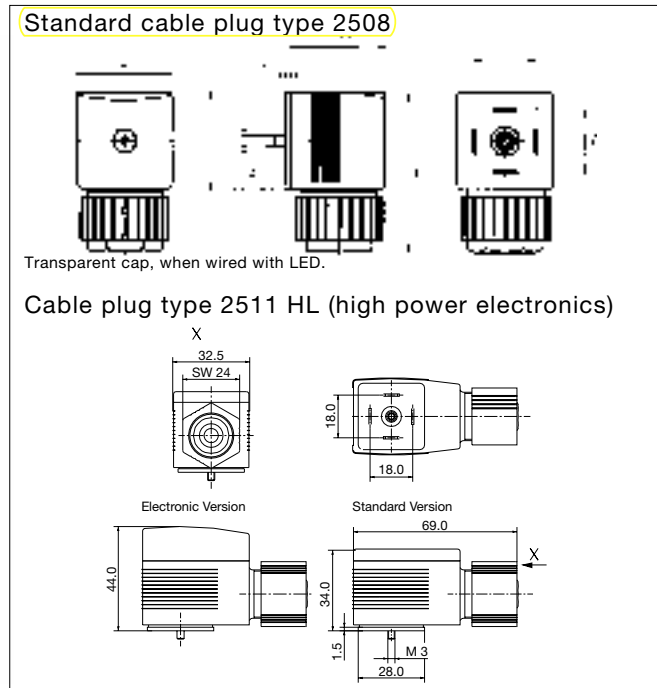
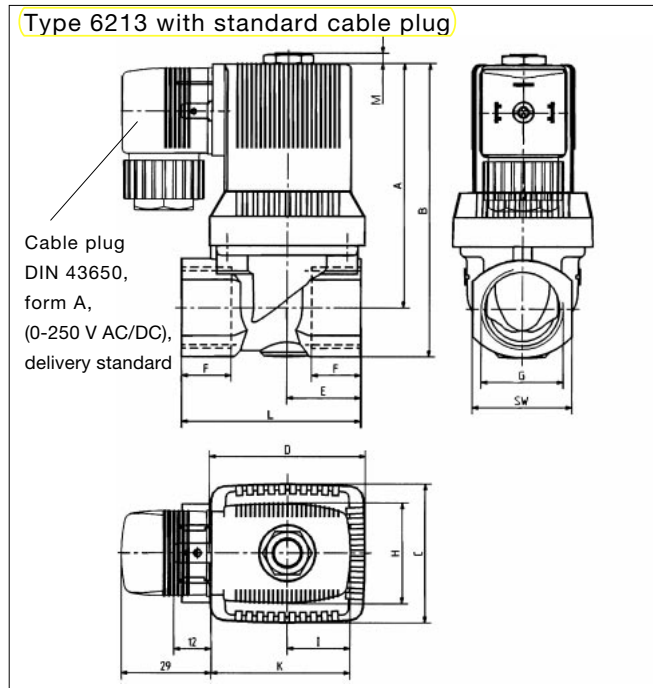

Standard versions

Threaded port [inch]	Orifice [mm]	Voltage	A [mm]	B [mm]	H [mm]	I [mm]	K [mm]	C [mm]	D [mm]	E ¹ (Brass) [mm]	E ² (S. St.) [mm]	F [mm]	L ¹ (Brass) [mm]	L ² (S. St.) [mm]	SW [mm]	M [mm]
G 1/4	10.0	AC	68.0	82.0	32.0	20.5	45.0	37.5	38.0	20.0	25.0	12.0	50.0	55.0	27.0	3.5
G 3/8	10.0		68.0	82.0	32.0	20.5	45.0	37.5	38.0	20.0	25.0	12.0	50.0	55.0	27.0	3.5
G 1/2	13.0		79.5	95.5	32.0	20.5	45.0	45.0	50.5	24.0	31.0	14.0	58.0	65.0	32.0	3.5
G 3/4	20.0		95.0	115.5	32.0	20.5	45.0	66.0	66.0	35.0	50.0	16.0	80.0	100.0	41.0	3.5
G 1/4	10.0	DC	68.5	82.5	40.0	23.5	51.0	37.5	38.0	20.0	25.0	12.0	50.0	55.0	27.0	3.5
G 3/8	10.0		68.5	82.5	40.0	23.5	51.0	37.5	38.0	20.0	25.0	12.0	50.0	55.0	27.0	3.5
G 1/2	13.0		80.0	96.0	40.0	23.5	51.0	45.0	50.5	24.0	31.0	14.0	58.0	65.0	32.0	3.5
G 3/4	20.0		95.5	116.0	40.0	23.5	51.0	66.0	66.0	35.0	50.0	16.0	80.0	100.0	41.0	3.5
G 1	25.0	AC/UC	138.0	158.5	49.0	24.5	53.0	78.0	78.0	40.5	-	18.0	95.0	-	41.0	7.0
G 1 1/4	25.0		138.0	163.0	49.0	24.5	53.0	78.0	78.0	40.5	-	20.0	95.0	-	50.0	7.0
G 1 1/2	40.0		149.5	179.5	49.0	24.5	53.0	104.5	104.5	69.0	-	22.0	132.0	-	60.0	7.0
G 2	40.0		149.5	184.5	49.0	24.5	53.0	104.5	104.5	69.0	-	24.0	132.0	-	70.0	7.0

Heavy duty versions

Threaded port [inch]	Orifice [mm]	Voltage	A [mm]	B [mm]	H [mm]	I [mm]	K [mm]	C [mm]	D [mm]	E ¹ (Brass) [mm]	E ² (S. St.) [mm]	F [mm]	L ¹ (Brass) [mm]	L ² (S. St.) [mm]	SW [mm]	M [mm]
G 1/2	13.0	AC/UC	102.5	118.5	43.0	21.5	50.0	45.0	50.5	24.0	31.0	14.0	58.0	65.0	32.0	7.0
G 3/4	13.0		102.5	118.5	43.0	21.5	50.0	45.0	50.5	24.0	31.0	16.0	58.0	65.0	32.0	7.0
G 3/4	20.0		118.0	138.5	49.0	24.5	53.0	66.0	66.0	35.0	50.0	16.0	80.0	100.0	41.0	7.0
G 1	20.0		118.0	138.5	49.0	24.5	53.0	66.0	66.0	35.0	50.0	18.0	80.0	100.0	41.0	7.0

Ordering Chart for Accessories

A wide selection of further cable plugs is available (see special data sheet Type 2508)